

TS2 BAGSEALER



Select Bag Sealers Ltd produces a manual tape bag sealer for a wide range of products and industries. Predominantly designed for the Bakery industry the TS2 can also be applied to the Fruit and Vegetable produce market and both the chilled and frozen meat industry.

The easy open tape seal makes it ideal for customers that need the bag to be opened several times and re-sealed in order to maintain freshness of product. The hot foil printer allows essential point of tie information such as trace-ability codes, best before dates, product prices, etc to be printed during the sealing procedure, removing the requirement for addition labels to be applied.



Easy to open and reseal.



Features and Benefits

- ✓ Safe and secure sealing of plastic and paper bags
- ✓ Re-useable, clearly printed, easy open seal
- ✓ Easy to operate hot foil printing system enables fast change of the product information printed on the seal
- ✓ Can be used with a wide range of coloured adhesive tape
- ✓ Low maintenance design with all components easily accessible
- ✓ Optional neck trimmer available

“Over the past 20 years we have perfected the art of tape bag sealing and are now keen to share our expertise globally”

Tom Foster MD



TS2 BAGSEALER

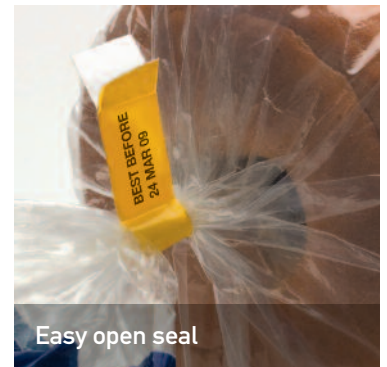
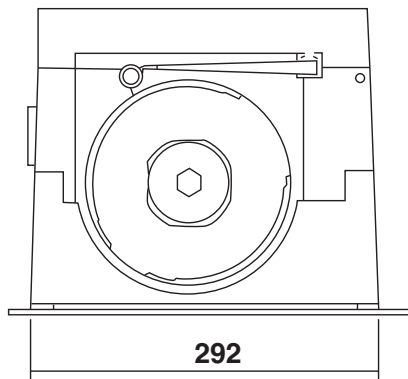
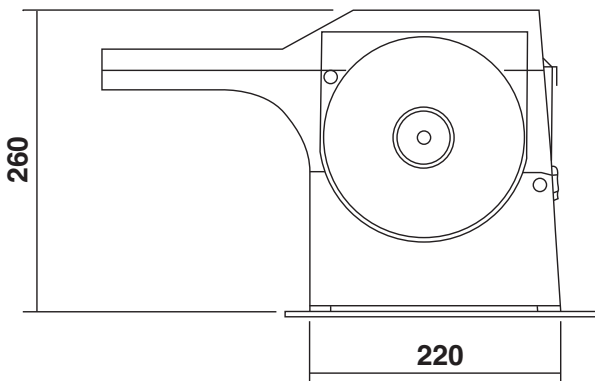
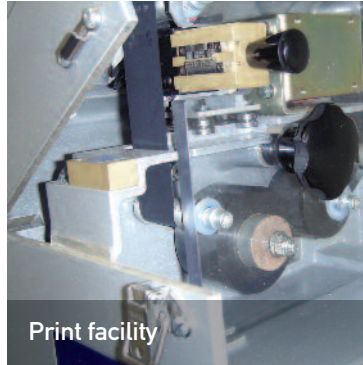
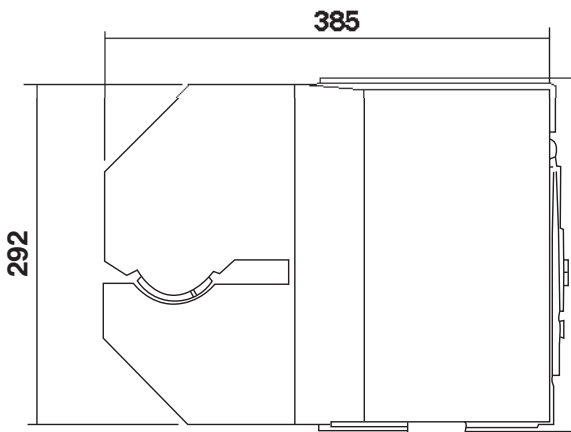

Technical Information

Adhesive Tape Size:

12mm wide by up to 330 metre long reels

Paper Tape Size:

11mm wide by up to 164 metre long reels

Hot Foil Tape Size:

32mm wide x 153 metres

Electrical Supply:

110 or 240v, single phase

Net Weight:

19kg

Machine complies with latest CE regulations

SELECT BAG SEALERS LIMITED

CHENGATE HOUSE, 61 PEPPER ROAD, HUNSLET LEEDS, LS10 2RU, UNITED KINGDOM

Tel: +44 (0)113 277 3169 | Fax: +44 (0)113 270 8733 E-mail: info@selectbagesealers.com

www.selectbagesealers.com

